



Finance Department

David P. Schmiedicke, Finance Director

City-County Building, Room 406
210 Martin Luther King, Jr. Boulevard
Madison, Wisconsin 53703
Phone: (608) 266-4521
Fax: (608) 266-5948

finance@cityofmadison.com
www.cityofmadison.com/finance/purchasing

Purchasing Services

REQUEST FOR QUOTATION

RFQ #: 5305-0-2024-TJ
For: Sign Blanks
Released Date: February 19, 2024
Due Date: March 04, 2024 @ 2:00 PM CST
City Agency: Traffic Engineering

Method of Delivery Options

Email Quotation to: bids@cityofmadison.com

1 GENERAL CONDITIONS AND INSTRUCTIONS TO BIDDERS

1.1 Applicable Terms and Conditions

- Products or Equipment. All quotations for supplies and/or equipment must be submitted in accordance with the specifications contained in this solicitation and City of Madison Standard Terms and Conditions.
- Services. All quotations for services must be submitted in accordance with; the specifications contained in this solicitation, City of Madison Standard Terms and Conditions, and Purchase of Services Contract.
- Copies. Copies of above-referenced forms are available from the Purchasing Office or from the following link:
<https://www.cityofmadison.com/finance/purchasing/vendor-resources>

1.2 Delivered Prices Only

Prices quoted must include shipping charges, FOB Madison.

1.3 Substitutes

If offering a substitute item, include manufacturer, number, model, specifications and product literature. The City will evaluate substitutes and make the final determination of equivalency.

1.4 Partial Order

Unless otherwise noted, it will be assumed that bidder will accept an order for all, or part of the items priced.

1.5 Award

The City will award the bid to the responsive and responsible bidder whose bid is most advantageous to the City. In determining the most advantageous bid, the City will consider criteria such as, but not limited to, cost, quality/workmanship, compatibility, standardization, major and minor exceptions to our specifications, superior design features, warranty, delivery, past experience, installation, equality, discount, customer satisfaction, bidder's past performance and/or service reputation, and service capability. The City may opt to establish alternate selection criteria to protect its best interest or meet performance or operational standards. After the due date, no quotes may be withdrawn for a period of 90 days or as otherwise specified or provided by law.

2 CONTACTS

Technical:	For questions regarding technical specifications.	Ed Smith City of Madison Traffic Engineering (608) 266-9034 ersmith@cityofmadison.com
Buyer:	For questions regarding instructions, terms & conditions.	Tammy Jones City of Madison Purchasing Services bids@cityofmadison.com

3 BID DISTRIBUTION NETWORK

Please note that the City no longer maintains an in-house bidders' list. **Notification of bid opportunities, addenda, tabulations and awards will only be made to subscribers via these networks.**

State of Wisconsin VendorNet System: [State of Wisconsin and local agencies bid network. Registration is free. http://vendornet.state.wi.us/vendornet](http://vendornet.state.wi.us/vendornet)

DemandStar by Onvia: National bid network – Free subscription is available to access bids from the City of Madison and other Wisconsin agencies, participating in the Wisconsin Association of Public Purchasers (WAPP). A fee is required if subscribing to multiple agencies that are not included in WAPP.

Bid Opportunities: www.cityofmadison.com/finance/purchasing/bidDemandStar.cfm

Home Page: www.demandstar.com

To Register: <https://www.demandstar.com/app/registration>

Please note when registering: Pick the **Wisconsin Association of Public Procurement (WAPP)** to select all current Wisconsin government agencies.

4 LOCAL VENDOR PREFERENCE

The City of Madison has adopted a local preference purchasing policy granting a scoring preference to local suppliers. Only suppliers registered as of the bid's due date will receive preference. Learn more and register at the City of Madison website.

www.cityofmadison.com/business/localPurchasing

5 SPECIFICATIONS

The City of Madison Traffic Engineering is seeking qualified quotes for sign blanks. Please see below specifications:

- Blanks are to be aluminum alloy #5052-H38.
- Deburred with smooth Edges.
- Coated with Alodine 1200S.
- 1-1/2" corner radius unless otherwise specified in blank description.

The winning vendor is expected to provide cut sheets on the blanks for review before drilling the holes.

Please see the attached Appendices:

- Appendix A – Typical street name sign drawing
- Appendix B – Octagon cut sheet.
- Appendix C – Pentagon cut sheet.

Item Number	Sign Description	Quantity
1	15"x 21" x 0.080" with 4 each 7/16" holes, 1-1/2" in from each edge, on centerlines, 12" C to C and 18" C to C	500
2	18" x 18" x 0.080" with 4 each 7/16" holes, 1 each 1-1/2" in from top and bottom edges, on centerline, 15" C to C and 1 each 2-1/4" in from opposite corners, on centerline, 19" C to C	50
3	18" x 24" x 0.080" with 4 each 7/16" holes, 1-1/2" in from top and bottom edge on centerlines, 15" C to C and 21" C to C	250
4	18" x 30" x 0.080" with 4 each 7/16" holes, 1-1/2" in from each edge on centerline, 15" C to C and 27" C to C	50
5	18" x 66" x 0.125" no holes, with 1-1/2" radius corners	10
6	18" x 72" x 0.125" no holes, with 1-1/2" radius corners	10
7	24" x 12" x 0.080" with 4 each, 7/16" holes, 1-1/2" in from each edge on centerlines, 21" C to C and 9" C to C	400
8	24" x 24" x .080" with 4 ea. 7/16" holes, 1 each 1-1/2" in from top and bottom edges, on centerline, 21" c to c and 1 each 2-1/2" in from opposite corners on centerline, 27-3/4" C to C	150
9	24" x 30" x 0.080" with 4 each 7 /16" holes, 1 each 1-1/2" in from each edge on centerlines, 21" C to C and 27" C to C	300
10	24" x 48" x 0.080" with 4 each 7/16" holes, 1-1/2" in from each edge, on centerlines, 21" C to C and 45" C to C	35

11	30" octagon x 0.080" with 2 each 7/16" holes, 1 each 3" in from top and bottom edges, on centerline, 24" C to C	100
12	30" pentagon x 0.080" with 2 each 7/16" holes, in 2" from bottom edge, and 4-7/8" from the top 22-3/8" C to C	50
13	30" x 30" x 0.080" with 4 each 7/16" holes, 1 each 1-1/2" in from top and bottom edges on centerline, 27" C to C, and 1 each 2-1/2" in from opposite corners on centerline, 36-1/4" C to C	200
14	30" x 9" x 0.125" street name sign with 4 each 7/16" holes, 2 each top and 2 each bottom, 1/2" in from edge to center of holes, 4" apart, c to c horizontally. see appendix a "Typical street name sign" drawing	150
15	12" x 6" x 0.125" with 2 each 7/16" holes, in 1-1/2" from edge on centerline, 9" C to C	200
16	9" x 12" x 0.080" with 4 each 7/16" holes, 1" in from each edge on centerlines, 7" C to C and 10" C to C	50
17	18" x 6" x 0.125" with 2 ea. 7/16" holes, 1" from top and bottom edge on centerline, 4" C to C	50

Delivery:

Prices should include delivery to the below address:

City of Madison Traffic Engineering
 1120 Sayle Street
 Madison, WI 53715

An advance notice of 24-48 hours is required prior to delivery, please contact Ed Smith via phone 608-266-9034 or email ersmith@cityofmadison.com.

The receiving facility does not have a loading dock, so please ship accordingly, flatbed is preferred. If no flatbed is available, the driver must move pallets to back of truck for unloading.



Form A: Price Proposal

RFQ #: 5305-0-2024-TJ Sign Blanks

This form must be returned with your response.

Complete the requested information and return via instructions on Page 1 of RFQ. Bidder hereby offers:

Item Number	Sign Description	Quantity	Unit Price	Extended Price
1	15"x 21" x 0.080" with 4 each 7/16" holes, 1-1/2" in from each edge, on centerlines, 12" C to C and 18" C to C in conformance with the specifications described in this solicitation. Days to Delivery ARO:	500	\$	\$
2	18" x 18" x 0.080" with 4 each 7/16" holes, 1 each 1-1/2" in from top and bottom edges, on centerline, 15" C to C and 1 each 2-1/4" in from opposite corners, on centerline, 19" C to C in conformance with the specifications described in this solicitation. Days to Delivery ARO:	50	\$	\$
3	18" x 24" x 0.080" with 4 each 7/16" holes, 1-1/2" in from top and bottom edge on centerlines, 15" C to C and 21" C to C in conformance with the specifications described in this solicitation. Days to Delivery ARO:	250	\$	\$
4	18" x 30" x 0.080" with 4 each 7/16" holes, 1-1/2" in from each edge on centerline, 15" C to C and 27" C to C in conformance with the specifications described in this solicitation. Days to Delivery ARO:	50	\$	\$
5	18" x 66" x 0.125" no holes, with 1-1/2" radius corners in conformance with the specifications described in this solicitation. Days to Delivery ARO:	10	\$	\$
6	18" x 72" x 0.125" no holes, with 1-1/2" radius corners in conformance with the specifications described in this solicitation. Days to Delivery ARO:	10	\$	\$
7	24" x 12" x 0.080" with 4 each, 7/16" holes, 1-1/2" in from	400	\$	\$

	<p>each edge on centerlines, 21" C to C and 9" C to C</p> <p>in conformance with the specifications described in this solicitation.</p> <p>Days to Delivery ARO:</p>			
8	<p>24" x 24" x .080" with 4 ea. 7/16" holes, 1 each 1-1/2" in from top and bottom edges, on centerline, 21" c to c and 1 each 2-1/2" in from opposite corners on centerline, 27-3/4" C to C</p> <p>in conformance with the specifications described in this solicitation.</p> <p>Days to Delivery ARO:</p>	150	\$	\$
9	<p>24" x 30" x 0.080" with 4 each 7/16" holes, 1 each 1-1/2" in from each edge on centerlines, 21" C to C and 27" C to C</p> <p>in conformance with the specifications described in this solicitation.</p> <p>Days to Delivery ARO:</p>	300	\$	\$
10	<p>24" x 48" x 0.080" with 4 each 7/16" holes, 1-1/2" in from each edge, on centerlines, 21" C to C and 45" C to C</p> <p>in conformance with the specifications described in this solicitation.</p> <p>Days to Delivery ARO:</p>	35	\$	\$
11	<p>30" octagon x 0.080" with 2 each 7/16" holes, 1 each 3" in from top and bottom edges, on centerline, 24" C to C</p> <p>in conformance with the specifications described in this solicitation.</p> <p>Days to Delivery ARO:</p>	100	\$	\$
12	<p>30" pentagon x 0.080" with 2 each 7/16" holes, in 2" from bottom edge, and 4-7/8" from the top 22-3/8" C to C</p> <p>in conformance with the specifications described in this solicitation.</p> <p>Days to Delivery ARO:</p>	50	\$	\$
13	<p>30" x 30" x 0.080" with 4 each 7/16" holes, 1 each 1-1/2" in from top and bottom edges on centerline, 27" C to C, and 1 each 2-1/2" in from opposite corners on centerline, 36-1/4" C to C</p> <p>in conformance with the specifications described in this solicitation.</p> <p>Days to Delivery ARO:</p>	200	\$	\$
14	<p>30" x 9" x 0.125" street name sign with 4 each 7/16" holes, 2 each top and 2 each bottom, 1/2" in from edge to center of holes, 4" apart, c to c horizontally. see appendix a "Typical street name sign" drawing.</p>	150	\$	\$

	in conformance with the specifications described in this solicitation. Days to Delivery ARO:			
15	12" x 6" x 0.125" with 2 each 7/16" holes, in 1-1/2" from edge on centerline, 9" C to C in conformance with the specifications described in this solicitation. Days to Delivery ARO:	200	\$	\$
16	9" x 12" x 0.080" with 4 each 7/16" holes, 1" in from each edge on centerlines, 7" C to C and 10" C to C in conformance with the specifications described in this solicitation. Days to Delivery ARO:	50	\$	\$
17	18" x 6" x 0.125" with 2 ea. 7/16" holes, 1" from top and bottom edge on centerline, 4" C to C in conformance with the specifications described in this solicitation. Days to Delivery ARO:	50	\$	\$

ARO: After Receipt of Order

Above bid submitted by:



Form B: Bidder Information

RFQ #: 5304-0-2024-TJ Sign Blanks

This form must be returned with your response.

BIDDER INFORMATION

COMPANY NAME			
ADDRESS	CITY	STATE	ZIP
BIDDER'S NAME	TITLE		
EMAIL			
SIGNATURE	TELEPHONE NUMBER		
DATE	FAX NUMBER		

LOCAL VENDOR STATUS

The City of Madison has adopted a local preference purchasing policy granting a scoring preference to local suppliers. Only suppliers registered as of the bid's due date will receive preference. Learn more and register at the City of Madison website.

CHECK ONLY ONE:

- Yes**, we are a local vendor *and* have registered on the City of Madison website under the following category: _____ www.cityofmadison.com/business/localPurchasing
- No**, we are not a local vendor or have not registered.

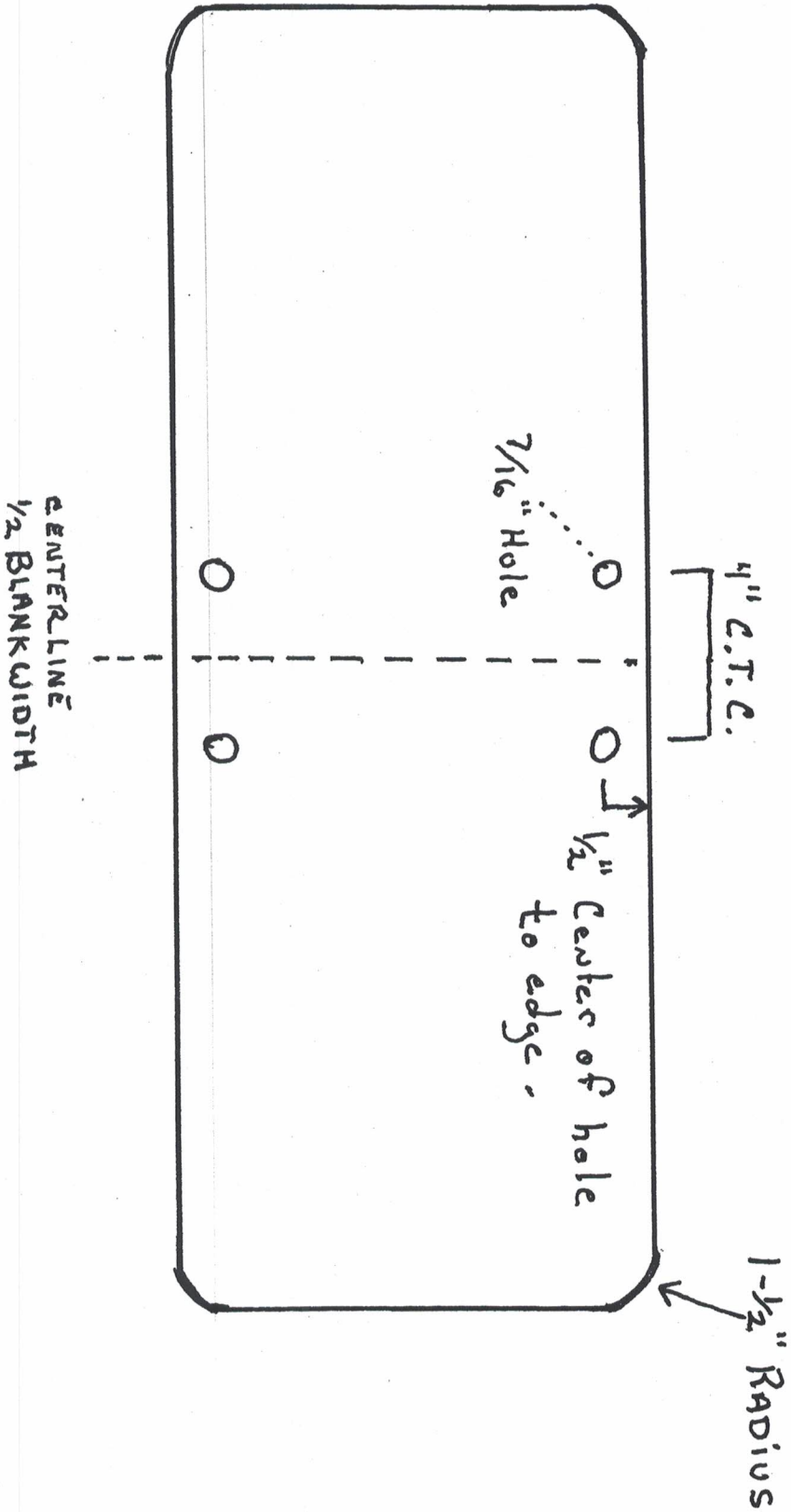

TYPICAL STREET NAME SIGN BLANK

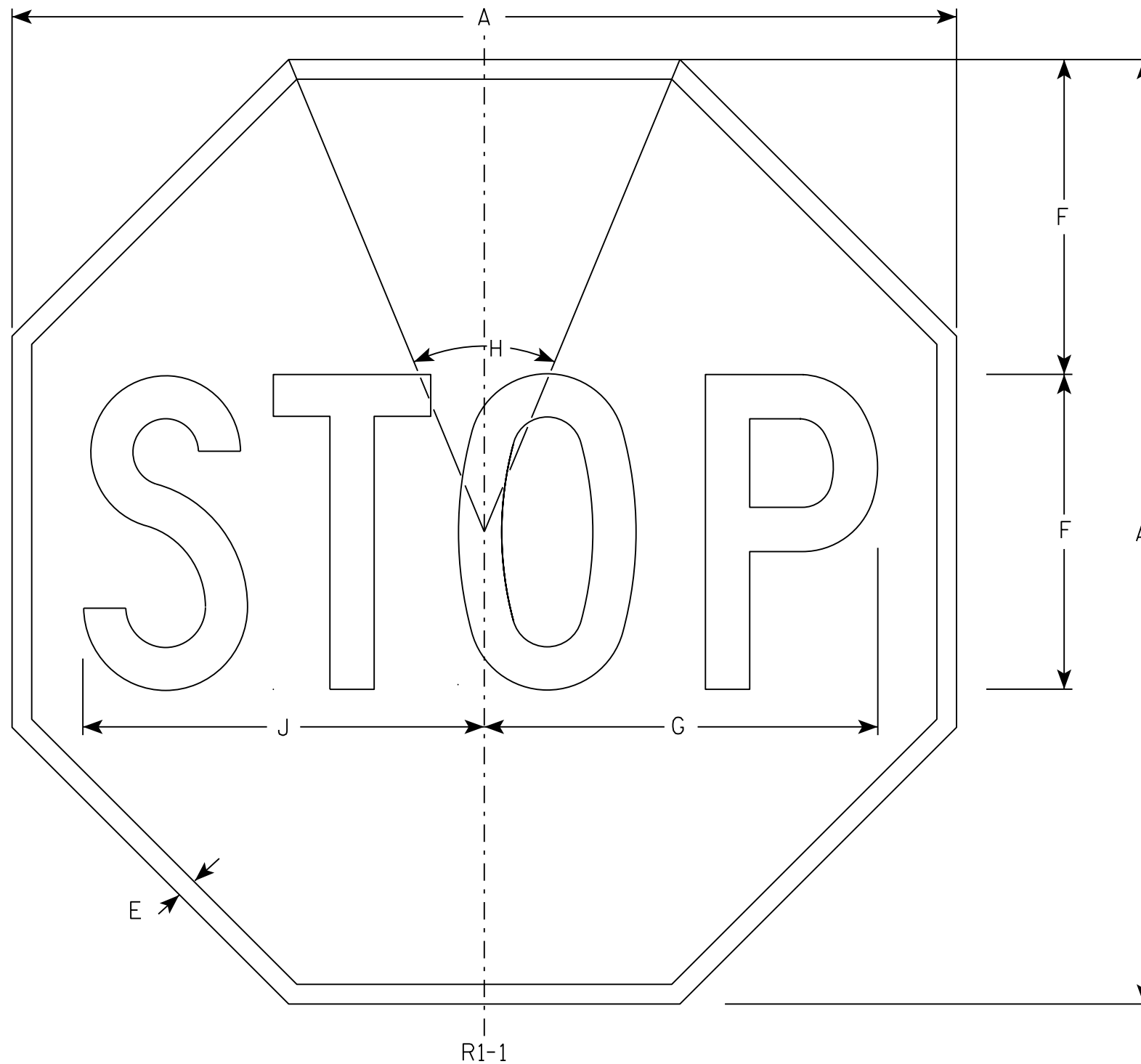

NOTES

1. Sign is Type II - Type H Reflective - reference WIS DOT Standard Specification for HIGHWAY and STRUCTURE CONSTRUCTION latest edition.
2. Color:
Background - Red
Message - White
3. Message Series - C

7

7

R1-1

SIZE	A	B	C	D	E	F	G	H	I	J	K	L	M	N	O	P	Q	R	S	T	U	V	W	X	Y	Z	Area sq. ft.
1	30				5/8	10	12 1/2	45°		12 3/4																	5.18
2S	30				5/8	10	12 1/2	45°		12 3/4																	5.18
2M	36				3/4	12	15	45°		15 3/8																	7.46
3	36				3/4	12	15	45°		15 3/8																	7.46
4	48				1	16	20	45°		20 1/2																	13.25
5	48				1	16	20	45°		20 1/2																	13.25
6	18				3/8	6	7 3/4	45°		7 3/4																	1.86
7	12				1/4	4	5	45°		5 1/8																	0.78

STANDARD SIGN
R1-1

WISCONSIN DEPT OF TRANSPORTATION

APPROVED *Matthew R. Rauch*
for State Traffic Engineer

DATE 11/12/15 PLATE NO. R1-1.13

PROJECT NO: _____ HWY: _____ COUNTY: _____ SHEET NO: _____ **E**

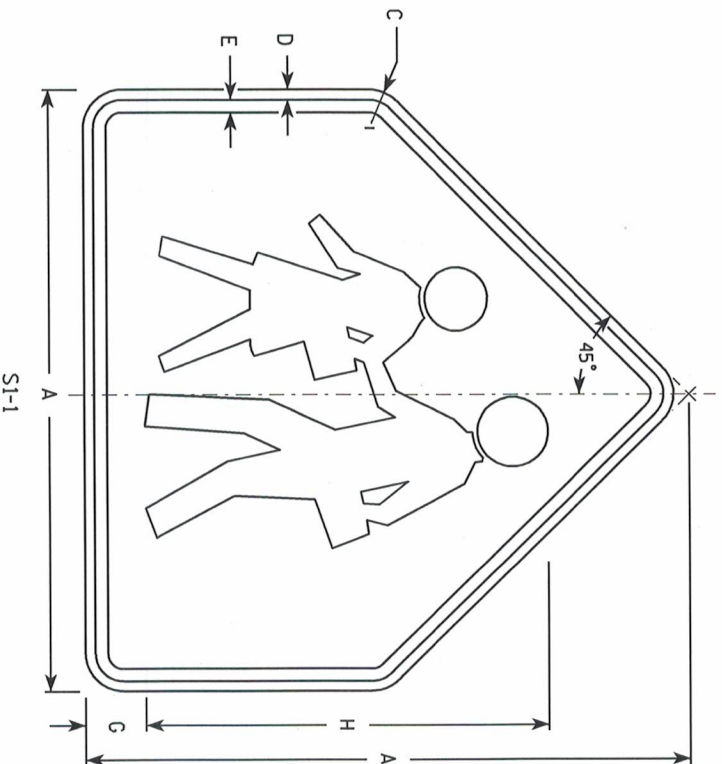

NOTES

1. Sign is Type II - Type F Reflective - reference WIS DOT Standard Specification for HIGHWAY and STRUCTURE CONSTRUCTION latest edition.
2. Color:
Background - Yellow-Green
Message - Black
3. Corners may be square or rounded when base material is plywood but borders shall be rounded as shown. When base material is metal, the corners and borders shall be rounded.

SIZE	A	B	C	D	E	F	G	H	I	J	K	L	M	N	O	P	Q	R	S	T	U	V	W	X	Y	Z	Area sq. ft.
1	30		1 3/8	1/2	5/8		3	20																			4.69
2	36		1 3/8	3/8	3/4		3 1/2	24																			6.75
3	36		1 3/8	3/8	3/4		3 1/2	24																			6.75
4	48		2 1/4	3/4	1		4 3/8	32																			12
5																											

STANDARD SIGN
S1-1

WISCONSIN DEPT OF TRANSPORTATION
APPROVED
Matthew R. Rauch
DATE 6/30/05
PLATE NO. S1-1B

7

7